



# Productivity of digital fabrication in construction: Cost and time analysis of a robotically built wall

Borja García de Soto<sup>a,b,\*</sup>, Isolda Agustí-Juan<sup>c</sup>, Jens Hunhevicz<sup>d</sup>, Samuel Joss<sup>d</sup>, Konrad Graser<sup>d</sup>, Guillaume Habert<sup>c</sup>, Bryan T. Adey<sup>c</sup>

<sup>a</sup> New York University Abu Dhabi (NYUAD), Saadiyat Island, Division of Engineering, Experimental Research Building, P.O. Box 129188, Abu Dhabi, United Arab Emirates

<sup>b</sup> New York University (NYU), Tandon School of Engineering, 6 MetroTech Center, Brooklyn, NY 11201, USA

<sup>c</sup> Institute of Construction and Infrastructure Management, ETH Zurich, Stefano-Franscini-Platz 5, Zurich 8093, Switzerland

<sup>d</sup> ETH Zurich, NCCR Digital Fabrication, Stefano-Franscini-Platz 1, Zurich 8093, Switzerland

## ARTICLE INFO

### Keywords:

3D printing  
Additive manufacturing  
Construction automation  
Construction industry  
Digital fabrication  
Industrialized construction  
Labor productivity  
Robot system  
Robotic construction

## ABSTRACT

Although automation has been actively and successfully used in different industries since the 1970s, its application to the construction industry is still rare or not fully exploited. In order to help provide the construction industry with an additional incentive to adopt more automation, an investigation was undertaken to assess the effects of digital fabrication (dfab) on productivity by analyzing the cost and time required for the construction of a robotically-fabricated complex concrete wall onsite. After defining the different tasks for the conventional and robotically fabricated concrete wall, data was collected from different sources and used in a simulation to describe the distribution of time and cost for the different construction scenarios. In the example, it was found that productivity is higher when the robotic construction method is used for complex walls, indicating that it is possible to obtain significant economic benefit from the use of additive dfab to construct complex structures. Further research is required to assess the social impacts of using dfab.

## 1. Introduction

### 1.1. Productivity problem in the construction sector

The built environment is a sector of high strategic importance for each economy. With annual revenues of nearly 10 trillion USD, or about 6% of global GDP, the engineering and construction industry is a cornerstone of the world's economy [1]. However, studies show that the construction sector's productivity has been stagnating in recent decades worldwide and that it has not been able to keep pace with the overall economic productivity [2]. The causes are numerous and include factors such as the resistance to introduce changes in a highly traditional sector, low industrialization of construction processes, poor collaboration and data interoperability, and high levels of turnover, which make difficult to implement new methods [3].

The construction industry is facing challenges to improve the current situation and increase the overall productivity. One way of doing this could be, as suggested by Barbosa et al. [4], to adopt elements of the technology industry, such as cross-functional teams, with an emphasis on learning and deploying the latest technologies. For example,

researchers have found successful applications of scrum techniques from software project management to construction projects [5]. These management changes should be fully supported and integrated with new technological advancements. In that direction, Agarwal et al. [6] proposed a shift to a digital construction organization by exploiting and combining existing technologies such as rapid digital mapping, BIM, digital collaboration, internet of things, and future proof design and construction. Bock [2] shares this view and sees in the strategies coming from the general manufacturing industries under the notion of “industry 3.0” and “industry 4.0”, “in which highly autonomous and networked automation and robot systems cooperate to produce complex products with consistently sustained productivity” [2], the promise for the needed change in a construction industry that has been stagnating for decades. Bock summarizes this new set of technologies and processes under the term of “construction automation”. Another often heard term is digital fabrication (dfab), describing the link between digital technologies and the physical construction process [7], which will be used instead in this study.

\* Corresponding author at: New York University Abu Dhabi (NYUAD), Saadiyat Island, Division of Engineering, Experimental Research Building, P.O. Box 129188, Abu Dhabi, United Arab Emirates.

E-mail address: [garcia.de.soto@nyu.edu](mailto:garcia.de.soto@nyu.edu) (B. García de Soto).

<https://doi.org/10.1016/j.autcon.2018.04.004>

Received 15 December 2017; Received in revised form 27 March 2018; Accepted 14 April 2018

Available online 01 May 2018

0926-5805/ © 2018 Elsevier B.V. All rights reserved.

## 1.2. Digital fabrication processes and technologies for construction

The use of robots in construction has been investigated since the early 80s [8]. Warszawski [9] published one of the first critiques about the use of robots in the building sector and proposed different robot configurations to address different construction tasks. Skibniewski [10] presented an expert system for decision support in regard to implementing advanced robotic technology on the construction site; however the implementation of robots in construction sites is still limited. Nonetheless, their use will undoubtedly increase as more cost effective applications are found. The field of digital fabrication (dfab) is quite broad and has many applications. Dfab techniques are based on the combination of computational design methods and automated construction processes, which are typically categorized as subtractive, formative, or additive [11]. Subtractive fabrication involves the removal of material using electro-, chemically- or mechanically-reductive (multi-axis milling) processes. In formative fabrication mechanical forces, restricting forms, heat or steam are applied to reshape or deform a material. Finally, additive fabrication consists of incremental aggregation of material layer-by-layer through extrusion, assembly, binder jetting, etc. The use of subtractive and formative digital fabrication is becoming mainstream in the prefabrication (off-site) of building parts (e.g., by using laser cutting, CNC milling, etc.). Examples of these applications include the generation of a unique shape for each of the 10,000 gypsum fiber acoustic panels at the Hamburg Philharmonic by Herzog & de Meuron [12]. Other architects, such as Frank Gehry and Zaha Hadid have also employed similar digital fabrication processes in their projects [13]. In recent years, additive fabrication processes, especially 3D printing, have experienced a rapid development in many industries. As interest in additive fabrication grows, research into large-scale processes begins to reveal potential applications in construction [14]. Additive construction consists of material aggregation through diverse techniques such as assembly, lamination and extrusion. Existing additive dfab technologies can be classified in two big clusters: on-site and off-site construction technologies.

On the one hand, on-site digital fabrication aims to bring additive fabrication processes on construction sites. Sousa et al. [15] classified on-site technologies in three main categories: large-scale robotic structures, mobile robotic arms, and flying robotic vehicles. A well-known example from the first category is Contour Crafting, a robotic structure for 3D printing large-scale construction, developed at the University of Southern California [16]. An example of a mobile robot for on-site construction is the semi-automated mason (SAM) developed by construction Robotics [17], or the “In situ Fabricator” (IF), developed at ETH Zurich [18]. Finally, the use of flying robots in construction is a novel technique developed to avoid mobility constraints and the need for cranes on construction sites. Imperial College London developed an application of these technologies for polyurethane foam deposition [60]. On the other hand, off-site digital fabrication aims to custom-design and prefabricate large-scale complex architectural elements off-site. Among existing additive dfab technologies, the most common for prefabrication include gantry robots, fixed robotic arms, and 3D printers. For instance, the timber roof of the Arch\_Tec\_Lab at ETH Zurich was robotically fabricated and preassembled with a gantry robot at the ERNE Holzbau AG factory [19]. An example of additive prefabrication with a fixed robotic arm is the project DEMOCRITE from XtreeE and ENSA Paris-Malaquais. This project aims to construct complex concrete structural elements with increased performance and material optimization [20]. Finally, the use of 3D printers is currently investigated for prefabrication of architectural elements. The project D-Shape developed by Enrico Dini uses this technology for 3D printing sand structures through a binder-jetting process [21].

## 1.3. State of the art for additive digital fabrication

Digital fabrication techniques can increase productivity rates in the

building industry not only because they lead to significant time saving for complex designs, but also because they exhibit the ability to transfer design data directly to 1:1 assembly operations and automated construction [22]. However, additive dfab applied to large-scale construction is still in their infancy and need to face challenges on changing conventional construction processes and roles of project participants.

Initial attempts have been made to apply additive dfab in real practice to evaluate its potential for the construction sector. For instance, Gramazio Kohler Research at ETH Zurich has accomplished different building demonstrators constructed with robotic technologies. The brick façade of the Gantenbein Vineyard showed the possibilities of computational design and robotic construction for the prefabrication of complex multi-functional brick structures. As the robot could be driven directly by the design data, without having to produce additional implementation drawings, the designers were able to work on the design of the façade until the moment of starting production [23]. A more recent project “The Sequential Roof” successfully verified the potential of additive dfab processes for the prefabrication of complex timber structures at full building scale. This robotically assembled 2300 square meter roof is formed by 120 timber trusses, each one produced in 12 h. The development of robust computational design and automated construction framework allowed a reduction in construction time by 10 times [19]. Contributions have also been made for developing concrete structures, especially for non-standard building elements. For instance, the Concrete Printing process developed at Loughborough University consisted of the additive fabrication of full-scale building elements such as panels and walls with the use of a gantry robot. According to Lim et al. [24] this process enables design freedom, precision of manufacture with functional integration, and elimination of labor-intensive molding. There have been successful full-scale applications [14], the most recent by Apis Cor [25]. They have used a similar process for the construction of a 3D printed house in 24 h. The project presents a potential cost reduction up to 40% compared with a conventional concrete house [25].

Nevertheless, fewer research efforts have been made to investigate quantitatively the benefits that additive digital fabrication can provide to the construction sector. The state of the art includes quantitative studies in the field of sustainability assessment of digital fabrication, highlighting benefits such as material optimization or functional integration. For example, Agustí-Juan and Habert [26] evaluated the environmental potential of additive digital fabrication by assessing three case studies and comparing them with conventional building elements with same functionality. This study also brought up the need for finding the differences between conventional construction processes and dfab processes, while rarely being researched. It is still not clear yet to what extent the implementation of additive dfab techniques will improve the construction performance in real projects. However, to facilitate large-scale industrial applications, there is the requirement to conduct quantitative assessments that consider the construction time, cost, and design complexity of new techniques.

## 1.4. Goal and scope of the study

Construction productivity has been defined as “how well, how quickly, and at what cost buildings and infrastructure can be constructed” [27]. Although productivity is a very important metric, there is not a standard or official productivity index in the construction industry, which leads to some confusion when trying to compare different values [28]. The general consensus is that productivity denotes the output achieved by a given amount of input (i.e., a measure of how efficiently a worker transforms inputs to outputs) [29,30]. Output can be tons of rebar installed or cubic meters of concrete placed while input is generally the number of hours worked. When considering cost, the input can be the total cost (i.e., labor, material, and equipment costs) related to a given installed quantity. In these cases, it is more intuitive to use the inverse of output/input, to determine how much cost a fixed

unit of installed quantity (e.g., USD/m<sup>2</sup>), so that a lower USD/m<sup>2</sup> indicates an improved productivity.

Several studies have addressed the subject of productivity and cost analysis of construction robots. For instance, Warszawski [31] examined robot requirements, implementation and economic feasibility of their application. Skibniewski and Hendrickson [32] looked into the costs and benefits of applying robotics for on-site surface finishing work. This study concluded that the use of robots for repetitive surface application tasks can be viable from the technical and economical point of view. Similarly, Najafi and Fu [33] concluded that using robotics for simple and repetitive building tasks is more economic than conventional approaches. Balaguer et al. [34] highlighted the productivity advantages of robotized spraying panels in comparison with manual manufacturing. Castro-Lacouture et al. [35] looked into the productivity improvements for the automation of concrete paving operations and found that the production rate of the automated process was about 22% higher than the conventional one. The previous studies were mainly focused on the analysis of robots for single and repetitive tasks. In contrast, Warszawski and Rosenfeld [36] analyzed the feasibility of multipurpose robots for interior building tasks. Specifically, this study compared time and costs between robotized and manual work to demonstrate the potential productivity improvement associated with robotic construction. However, robotic systems had until now limited applications in construction due to constraints such as a restricted mobility on construction sites. During the last years, novel robotic construction technologies and processes have been developed and their potential contribution to improve the productivity of the building industry should be evaluated.

This study aims to fill this research gap and provide a case study of additive dfab using on-site robotic fabrication technology, in order to map an innovative construction process and evaluate the impact on construction productivity. Firstly, a general description of the Mesh Mould Wall (MMW) case study and its fabrication technique is given to highlight its features. Then the MMW is compared with a conventional reinforced concrete wall, with the same volume and functionality. The selected tool for conducting the quantitative assessment and comparative study is the CYCLONE discrete event simulation system, which is considered one of the most effective tool for modeling and analyzing construction operations [37]. This quantitative study enables us to evaluate the potential benefits that additive on-site robotic fabrication techniques bring to construction productivity with regards to different level of building complexity, and provides a critical view to reshape conventional construction processes.

## 2. Methodology

For the purposes of this study the productivity has been measured at the activity level in terms of cost and time according to Eq. (1).

$$P = \frac{I}{Q} \quad (1)$$

where  $P$  is productivity,  $I$  is, in the case of cost, the total cost (i.e., labor, material and equipment), and in the case of time the total workhours used, and  $Q$  is the installed quantity (e.g., cubic meters of concrete). Therefore, a decrease in the cost or time per unit of installed quantity indicates an increase in productivity. This could mean higher-quality structures at lower cost for owners, higher profitability for contractors, and higher wages for workers [4].

The main steps followed to conduct this study are summarized in



Fig. 1. Process to determine productivity.

Fig. 1. The process for which productivity would be calculated was defined considering different tasks and subtasks. For the different tasks, data was collected from different sources, including recording on-site activities using time-lapse photography, video recording, as well as conducting interviews with different participants from the NCCR Digital Fabrication team (dfab.ch). When information was not available, production rates (e.g., daily output and production hours) were taken from RSMMeans [38] and confirmed by industry experts.

In addition to ensuring that a new process works as intended, one should be able to quantify the cost and time-benefits when comparing it to a conventional process before determining whether the proposed new process is worth implementing or not. Given that different processes can differ significantly from each other in terms of methods, material and people involved, a meaningful comparison is not trivial. The conventional construction and additive dfab processes are compared for the construction of a structural element (in this study a cast-in-place reinforced concrete wall) with the same final volume but different levels of complexity (i.e., straight wall and double-curved wall). A schematic view of the double-curved wall used in this study is shown in Fig. 2. The collected data was used in a simulation to describe the distribution of time and cost for the different construction scenarios.

The different processes (i.e., using conventional construction and additive dfab) for each wall type (straight wall and double-curved wall) were evaluated in accordance with Fig. 1 to conduct a comparative assessment as shown in the Case study section below.

## 3. Case study

### 3.1. Description

The DFAB HOUSE, located in Dübendorf, Switzerland, consists of a modular research building where individual construction projects can be installed to test new building and energy technologies under real conditions. One of the units that compose the building is the DFAB HOUSE, a three-story module to stimulate the discourse on the impact of digital fabrication in architecture, industry and society. The owner of the NEST DFAB HOUSE, Empa (Swiss Federal Laboratories for Materials Science and Technology), has a close collaboration with the NCCR Digital Fabrication for the digital planning and construction. Four additive dfab research projects from this research group integrate the building unit, namely, (1) Mesh Mould Wall (MMW), (2) Smart Dynamic Casting, (3) Smart Slab, and (4) Spatial timber assembly. Specifically, the case study analyzed in this study is the MMW. For additional information the reader is directed to the website of the NEST Unit DFAB HOUSE [39].

#### 3.1.1. Mesh Mould Wall

The Mesh Mould Wall (MMW) is a freeform load bearing reinforced concrete wall envisioned to be built on-site using the In situ Fabricator. The wall structure is optimized by introducing the double curves to stiffen the wall. In contrast to a conventional reinforced concrete wall, it unifies the reinforcement and formwork into a single and densely robotically fabricated element: the steel mesh (see Fig. 3). The steel mesh is composed of steel wires up to Ø6 mm [40] and it has a tension yield strength of 500 N/mm<sup>2</sup>, the same as the reinforcement used for the conventional wall. The fabrication of the steel mesh consists of a robotic process that assembles vertical steel wires through bending, cutting and welding horizontal steel wires using an end effector attached to the robot In situ Fabricator (IF). Following the steel mesh

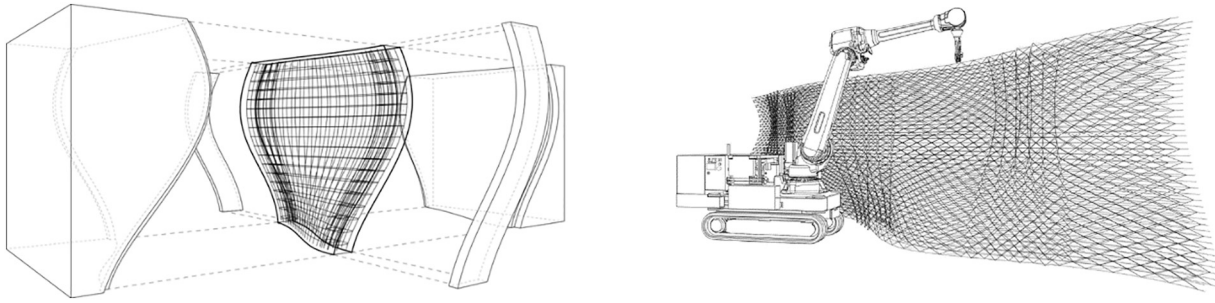

Fig. 2. Illustration of double-curved concrete wall built in conventional way (left) and additive dfab (right). (Source: Mesh Mould, Gramazio Kohler Research, ETH Zurich.)

fabrication, a special concrete mixture is placed to fill the mesh structure, where the steel mesh functions as a stay-in-place formwork. Concreting the mesh successfully requires that the concrete has sufficient compaction to avoid flowing out of the mesh, in other words, the properties of the concrete control the protrusion rate through the mesh and the roughness of wall surface. In response to this, the MMW uses a high-performance concrete mixture developed by Institute of Building Materials, ETH Zurich [41]. In general, the MMW construction can be classified as an additive digital fabrication process. Specifically, the main fabrication processes combined are material assembly and welding with an additive purpose. From a technology perspective, this case study employs a mobile robotic fabrication technology for on-site construction, as described in the next section.

### 3.1.2. In situ Fabricator

The In situ Fabricator (IF) is a semi-autonomous, mobile robot specifically designed for additive construction on-site. The height of the IF is the same as a standard wall and has a total weight of 1.4 tons. The IF robot is equipped with tracks driven by hydraulic motors, which can achieve a speed of 5 km/h. It is physically capable of moving on a non-flat terrain with obstacles found on a typical construction site. Moreover, it can be equipped with different tools or end effectors to perform a wide range of building tasks. Because construction sites are constantly changing and relatively dirty and cluttered environments, it is not possible to apply classical industrial automation approaches in controlling such systems. The IF is equipped with a camera-based sensing system for global localization of the robot in the construction site and for local detection of the element being built. The system can process architectural design decisions using Python code and then execute task loops over the whole building process. The camera sensing

allows to check between true measurements of the structure during build-up and provide less than 5 mm positioning accuracy at the end effector based on the architectural design data [18].

### 3.2. Define construction process

The planning and design of the robotically fabricated and the conventional concrete walls are not considered. Both construction processes start on the construction site and ends with the finished wall. It was assumed that all the material and equipment needed is on-site before construction begins. The curing time of the concrete is excluded.

The general process for the fabrication of the wall once the design is completed until the manual installation of the concrete work, is shown in Fig. 4.

The process for the robotic construction of a concrete wall (i.e., MMW and IF) was as shown in Fig. 5. Some of the tasks were further detailed to account for complete sequences (e.g., the last task of “Install and finish concrete” includes the following subtasks: place self-compacting concrete, apply shotcrete with fibers, apply shotcrete without fibers, and finish surface).

A steel plate with the shape of the wall serves as a base for the mesh. Mounting the steel plate to the floor is done manually. The positioning of the IF relative to the steel plate (i.e., localization) is done via attached AprilTags [43], which the IF recognizes through built-in cameras. It requires one worker supervising the IF and supplying rebar as needed. The IF fabricates the layers by bending the vertical rebar in the designated position and cutting and welding pieces of horizontal rebar to hold it in place on its own. The move of the IF to a new position after it reaches its maximum arm mobility is assisted by a worker to secure it to the new position. For more information about the IF the reader is



Fig. 3. Prototype of double-curved wall built with the Mesh Mould process. IF and MMW (left) and finished wall (right). (Source: [42].)

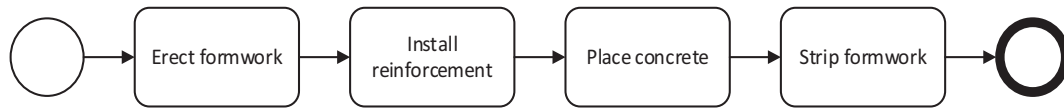

Fig. 4. Construction process used for conventional construction of a concrete wall.

referred to Gifftthaler et al. [18].

When the mesh is finished, it is manually filled with a specially designed self-compacting concrete [40], with the right consistency to leak out of the mesh as much as needed to satisfy a sufficient cover of the mesh. Although the finishing of the concrete is still ongoing research. Currently it is finished manually but a robotic refinement of the fresh concrete, or an additional layer of shotcrete could also be used. Fig. 6 shows a view of the IF building the Mesh Mould on EMPA NEST.

3.3. Characteristics of the concrete walls

The geometry of the double-curved and straight walls is summarized in Table 1.

3.3.1. Concrete

For the conventional construction, the concrete used was C25/30 with a compression strength of 25 N/mm<sup>2</sup>. For the Mesh Mould wall, Sika Monotop 412N was used [40].

3.3.2. Rebar

For the walls built using the conventional technique, a conventional B500B reinforcing steel was used. The mesh for the robotically fabricated walls consisted of 6 mm diameter vertical and 4 mm diameter horizontal steel wires. The steel used was B500A. Both with a tension yield strength of 500 N/mm<sup>2</sup>.

3.3.3. Formwork

The construction of conventional reinforced concrete walls requires a different formwork system according to the complexity of the structure. The formwork considered for the straight wall was job-built 3/4" (~19 mm) thick plywood. It was assumed that it could be reused four times without excessive repair [38]. The formwork for the double-curved wall consisted of a custom wood framework with hardened foam or Expanded Polystyrene (EPS) built to accommodate the desired shape. The installation of the EPS formwork (i.e., special formwork) is based on the installation of formwork in a conventional straight wall multiplied by complexity factors agreed on with different industry experts. The time related to the prefabrication and installation of the special formwork was considered for comparison purposes. The cost was obtained from interviews with fabricators of this type of special formwork and varied between 430 and 720 USD/m<sup>2</sup>. The EPS molds are fixed for a given shape and could be reused up to four times. If a new shape is needed, a new customized mold is required. After that, they have to be discarded. When using dfab, the cage formed by the 3D mesh is used as formwork. In addition, the shape is not fixed and can be modified as

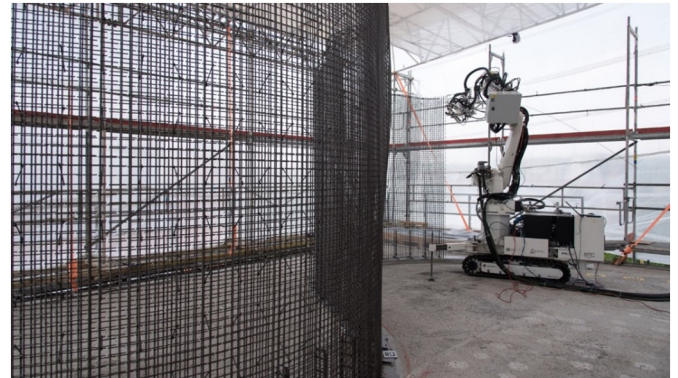

Fig. 6. In situ Fabricator building the Mesh Mould Wall. (Source: [42].)

Table 1  
Geometry of the double-curved and straight walls.

	Double-curved	Straight
Height (m)	2.80	2.50
Length (m)	12.20	11.70
Width (m)	0.13	0.15
Total area <sup>a</sup> (m <sup>2</sup> )	69.60	58.50
Volume (m <sup>3</sup> )	4.39 <sup>b</sup>	4.39

<sup>a</sup> The total area includes the area for two sides of the wall.

<sup>b</sup> Due to its complex geometry, the total volume for the double-curved wall was determined using the CAD model.

desired to meet architectural requirements.

3.4. Collect data

The data used for quantifying the time and related cost for the construction of the straight and double-curved walls with both construction processes was obtained by the authors. The data collection for the robotic construction process of the double-curved wall included on-site observations of different processes, time-lapse photography, video and interviews with different participants from the NCCR Digital Fabrication team. Moreover, cost and time data from the wall were collected from interviews with specialized contractors working on the DFAB HOUSE. In the case when information was not available, reasonable assumptions were made. In some cases, production rates (e.g., daily output and production hours) were taken from RSMeans [38] and

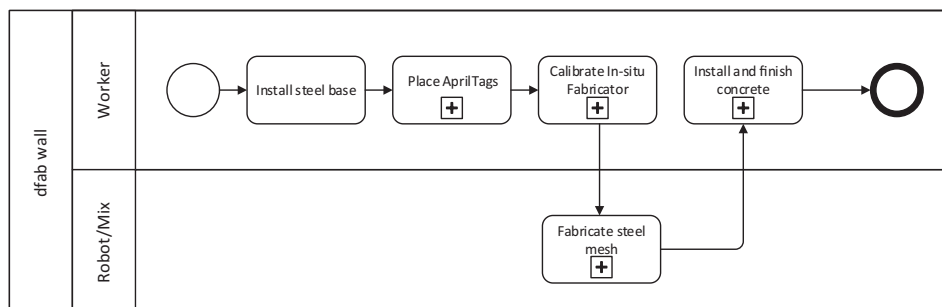

Fig. 5. Construction process used for robotically fabricated MMW using the IF.

**Table 2**  
Time (h) for straight concrete wall using conventional construction.

Task	No. workers	Time (h)		
		Optimistic	Most likely	Pessimistic
Erect & Strip formwork	4	N/A	14.95	N/A
Install reinforcement	3	N/A	0.90	N/A
Place concrete	3	N/A	8.37	N/A
Total		N/A	24.22	N/A

run by the NCCR Digital Fabrication team to ensure they were reasonable. The following sections summarize the data for each case.

3.4.1. Time data

The time associated to the different construction processes for the two wall types was based on the processes shown in Figs. 4 and 5.

3.4.1.1. Conventional construction. The time required for the construction of the conventional walls was estimated based on information provided by the contractor working on the DFAB HOUSE. The crew compositions were also based on conventional arrangement and proper allocation of workers for each task (e.g., for formwork, 3 carpenters and 1 laborer; for reinforcement 3 rodmen, etc.). The production rates used were provided by the contractor or from current literature (e.g., RSMMeans). The time (hours) required for the construction of the straight and double-curved walls using conventional construction is shown in Table 2 and Table 3 respectively.

3.4.1.2. Robotic fabrication. The time required for the construction of the robotically fabricated wall was based on the observations during the construction of the wall at the DFAB HOUSE. The times for the double-curved wall using dfab were obtained from the authors by taking time-lapse photography and videos during the construction as well as from interviews with different participants from the NCCR Digital Fabrication team. For the robotically fabricated straight wall, the values of the complex wall were adjusted to account for the simplicity of the straight wall. The time (hours) required for the construction of the straight and double-curved robotically fabricated walls is shown in Tables 4 and 5 respectively.

3.4.2. Optimization options for IF

The IF evaluated is currently in a prototypical phase and MM is the first building application in which this robot is tested. Consequently, the current functionality of the robot involves human intervention, as a separate tasks (e.g., install AprilTags, calibration, feeding rebar during the fabrication of the steel mesh, and setting/finishing concrete) or as a mixed tasks (e.g., securing the robot in next position and feeding wires during the fabrication of the 3D wire mesh). The share of work for the human, robot, and mixed work is shown in Fig. 7.

For a more realistic comparison with conventional construction, further adjustments affecting the functionally and performance of the IF should be considered. According to the MM team, the following improvements can be made: (1) the speed of production of one horizontal

**Table 3**  
Time (h) for double-curved wall using conventional construction.

Task	No. workers	Time (h)		
		Optimistic	Most likely	Pessimistic
Erect & Strip formwork <sup>a</sup>	4	35.57	44.46	53.35
Install reinforcement	3	4.60	6.13	7.67
Place concrete	3	16.75	20.93	25.12
Total		56.91	71.52	86.13

<sup>a</sup> Includes prefabrication time of special formwork.

**Table 4**  
Time (h) for the straight robotically fabricated wall.

Task	No. workers	Time (h)		
		Optimistic	Most likely	Pessimistic
Produce steel base	2	8.00	12.00	16.00
Place AprilTags	1	1.77	1.77	1.77
Calibrate IF	1	0.83	0.83	0.83
Fabricate steel mesh	1	33.03	33.67	34.51
Install and finish concrete	3	26.15	26.15	26.15
Total		69.78	74.42	79.27

**Table 5**  
Time (h) for the double-curved robotically fabricated wall.

Task	No. workers	Time (h)		
		Optimistic	Most likely	Pessimistic
Produce steel base	2	8.00	12.00	16.00
Place AprilTags	1	1.77	1.77	1.77
Calibrate IF	1	0.83	0.83	0.83
Fabricate steel mesh	1	36.10	36.50	37.27
Install and finish concrete	3	29.53	29.53	29.53
Total		76.23	80.63	85.40

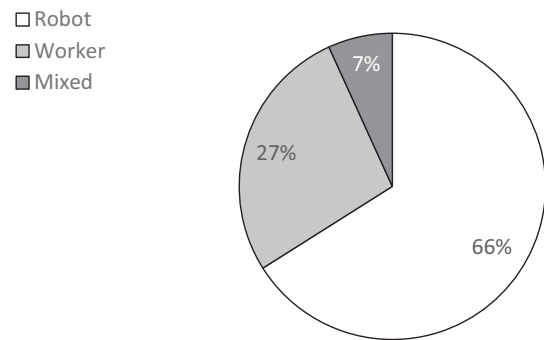

Fig. 7. Shared work (% of most likely total time) for the robotically fabricated wall with current condition.

rebar, specially its welding cycle, could be reduced to a third, from 6.8 s per cycle to about 2.3 s per cycle (i.e., Option 1: Faster Welding Cycle). (2) The limiting factor is the weight of the end-effector, so in addition to the modifications in Option 1, a lighter one could accelerate this step. The time to move down the end-effector (i.e., robot arm) could be cut in half, from currently 26 s to about 13 s (i.e., Option 2: Faster Robot Arm). The current feed of the rebar is done manually, so in addition to the modifications in Option 2, a higher speed could cause a rebound effect and affect the manual feed; however, if the feed is done automatically (i.e., Option 3: Automatic Rebar Exchange), this should not cause any problem and would improve the speed of the IF. Given the technological advancements in this field, these adjustments are considered, according to researchers from the MM team, reasonable and should be easily implemented in a commercial application of the IF.

3.4.3. Cost data

The cost and duration of the different construction processes for the two wall types was based on the processes shown in Figs. 4 and 5. Due to the nature of the DFAB HOUSE, the rates for the different workers involved would not have been realistic in real construction projects. For that reason, the hourly wages were adjusted to meet published rates. Being conservative, the RSMMeans-Building Construction Cost Data [38] was used. The rates from the RSMMeans are similar to those from the State Occupational Employment and Wage Estimates in New York published by the Bureau of Labor Statistics [44]. The costs used (i.e.,

**Table 6**  
Hourly wages for the different crew members (excluding OH&P).

Crew member	Hourly wage (USD)
Carpenter	48.45
Cement finisher	45.65
Equipment operator	51.10
Laborer	37.90
Rodman (reinforcement)	53.00
Skilled worker	49.90
Specialty technician/robot support	80.00

labor, material and equipment) do not include any markups for overhead and profit, i.e., they only represent the costs incurred by the contractor. The hourly wages used for the different crew members are summarized in Table 6.

The average daily crew cost for all the tasks was 1272 USD for the different tasks in the conventional construction and 784 USD for robotic fabrication. The crew allocation for the different tasks, as well as the daily cost, is shown in Figs. 8 and 9.

**3.4.3.1. Conventional construction.** The two concrete wall types built using the conventional construction followed the process shown in Fig. 4. The different cost types for the different tasks of each wall are summarized in Tables 7 and 8. When appropriate, an optimistic and pessimistic cost was considered to account for uncertainty in some tasks. Due to the low variability in the construction of the straight concrete wall using conventional construction, only the most likely costs were considered. The unit cost using conventional construction is about 1639 USD/m<sup>3</sup> and 12,425 USD/m<sup>3</sup> for the straight and double-curved concrete wall respectively.

**3.4.3.2. Robotic fabrication.** The two concrete wall types fabricated with the robotic fabrication technique followed the process shown in Fig. 5. The different cost types for the different tasks of each wall are summarized in Tables 9 and 10. When appropriate, an optimistic and pessimistic cost was considered to account for uncertainty in some tasks. The unit cost using robotic fabrication ranged between 4709 and 5341 USD/m<sup>3</sup> and between 4980 and 5606 USD/m<sup>3</sup> for the straight and double-curved concrete wall respectively.

The calculation of the robot cost proportional to a wall was determined using Eq. (2). The expected life of the robot ( $t_r$ ) was 90,000 h [45]. The IF is in an experimental phase and used for research purposes. It would be unrealistic to use its cost for this study as it would be significantly higher than the cost of similar robot system for commercial applications. Given current trends in the price of robots [46], it is expected that actual commercial robots with similar functionalities than the IF would be more economical than the one used for this case study. According to RobotWorx [47], the cost of new industrial robotics varies from 50,000 USD to 80,000 USD. The cost increases when application-specific peripherals are added. In that case, the robot system costs can range between 100,000 USD to 150,000 USD (“How much do industrial robots cost?”, n.d.). For this study, the cost of the robot ( $C_r$ ) was

assumed to be the average cost of an industrial robotic arm (125,000 USD).

$$C_w = C_r \frac{t_w}{t_r} \tag{2}$$

where  $C_w$  is the allocated cost of the robot (i.e., equipment cost) for the structure being built,  $C_r$  is the cost of the robot system including required peripherals,  $t_w$  is the time spent by the robot building the structure, and  $t_r$  is the expected life of the robot.

**3.5. Run simulations and get results**

The data collected was used to run simulations to determine the total time and cost for the different wall types and construction methods evaluated considering the variability observed. The simulations were done using the CYCLONE (CYCLic Operations NETWORK) modeling template of Simphony.NET (Simphony.NET 4.6, release Build 4.6.0.272 2017-08-11 [48]) using different distributions for the data. A total of 1000 runs were made for each scenario.

The results from the simulations (1000 iterations) for the total cost using the information from Tables 7 to 10 are summarized in Table 11.

Similarly, the results from the simulations (1000 iterations) for the total time using the information from Tables 2 to 5 are summarized in Table 12.

The mean time and percentage share for the human, robot, and mixed cases considering the current process and the optimization options for the IF (refer to Section 3.4.2 “Optimization options for IF”) for the robotic fabrication of the double-curved wall are shown in Fig. 10. The different options are used in the comparative analysis.

**3.6. Analyze data and calculate productivity**

Productivity for each wall/construction type was measured at the activity level in terms of cost and time according to Eq. (1). The unit of quantity installed considered for measuring the productivity of each wall was one cubic meter. This functional unit allowed a fair comparison between walls with different complexity level, dimensions, etc. The results are summarized in Table 13 (cost/unit quantity installed) and Table 14 (time/unit quantity installed).

**4. Results**

The results obtained from the simulations, based on the collected data, were used to calculate the productivity (i.e., USD/m<sup>3</sup> and h/m<sup>3</sup>) and conduct a quantitative comparison between the construction of the two wall types using the conventional and robotic fabrication methods. The results from this comparison are shown in Fig. 11 (USD/m<sup>3</sup>) and Fig. 13 (h/m<sup>3</sup>). The uncertainty associated with the increased level of complexity for the conventional construction is assumed to increase linearly using the maximum, minimum and mean values obtained from the simulation. This variation is shown for the optimistic and pessimistic cases. Expected reductions due to learning curve effects are not considered. For robotic construction, the productivity is shown as a

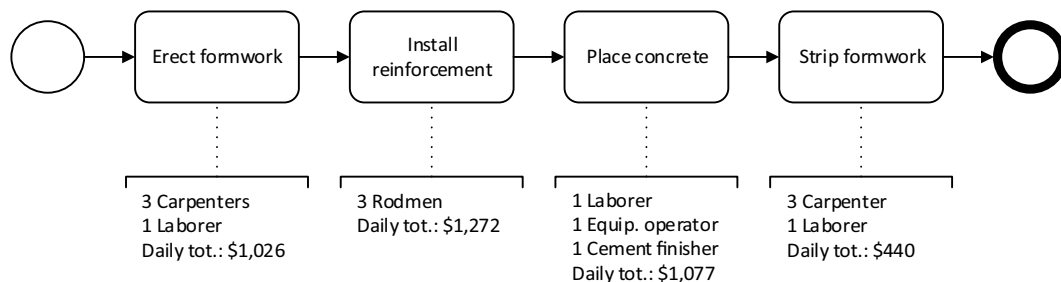

**Fig. 8.** Workers for the different tasks for construction of concrete wall using conventional construction.

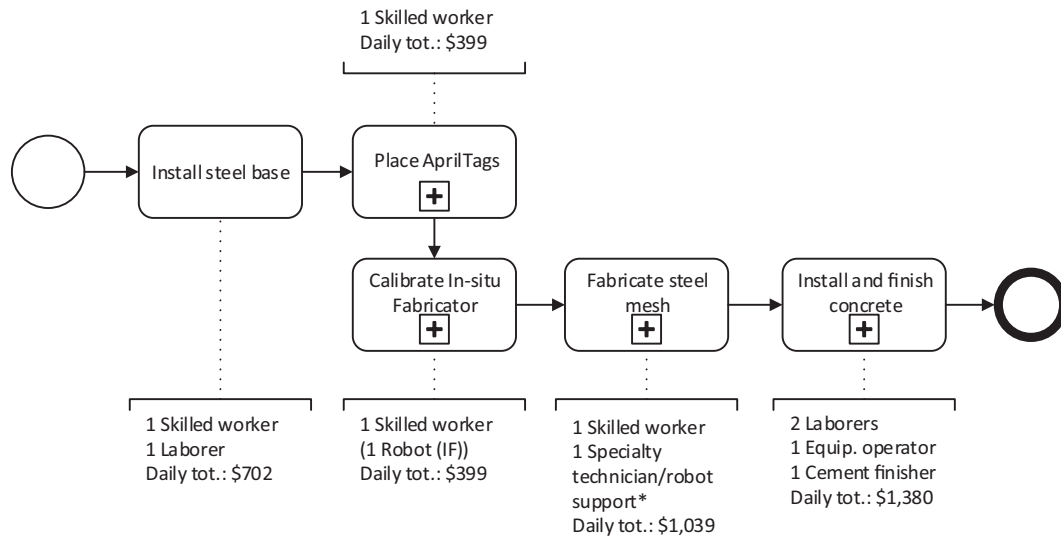

\* The cost of the specialty technician/robot support was only considered during the time the robot was in operation

Fig. 9. Workers for the different tasks for construction of concrete wall using robotic fabrication.

\*The cost of the specialty technician/robot support was only considered during the time the robot was in operation.

**Table 7**  
Cost for straight concrete wall using conventional construction.

Task	Cost type	Cost (USD)		
		Optimistic	Most likely	Pessimistic
Erect & Strip formwork	Labor	2739		
Erect & Strip formwork	Material	629		
Install reinforcement	Labor	143		
Install reinforcement	Material	100		
Place concrete	Labor	1127		
Place concrete	Material	955		
Place concrete	Equipment	1518		
	Total	7211		

**Table 8**  
Cost for double-curved wall using conventional construction.

Task	Cost type	Cost (USD)		
		Optimistic	Most likely	Pessimistic
Erect & Strip formwork	Labor	6517	8147	9776
Erect & Strip formwork	Material	30,067	40,090	50,112
Install reinforcement	Labor	731	975	1219
Install reinforcement	Material	166		
Place concrete	Labor	2255	2819	3382
Place concrete	Material	955		
Place concrete	Equipment	1518		
	Total	42,210	54,669	67,128

constant rate, indicating that the productivity is independent of the level of complexity. The variation shown is due to the different optimization options for the IF.

4.1. Cost per installed quantity (USD/m<sup>3</sup>)

Fig. 11 shows the productivity difference in USD/m<sup>3</sup> between the two wall types using robotic and conventional construction methods. As one can see, for the construction of a straight wall (i.e., with low level of complexity) there is not really an economic benefit by using dfab when compared to the conventional construction. This is the opposite in the case of the double-curved wall (very high level of complexity).

**Table 9**  
Cost for straight concrete wall using robotic fabrication.

Task	Cost type	Cost (USD)		
		Optimistic	Most likely	Pessimistic
Produce steel base	Labor	702	1054	1405
Produce steel base	Material	4635	4635	4635
Produce steel base	Equipment	1500	1500	1500
Place AprilTags	Labor	88	88	88
Calibrate IF	Labor	42	42	42
Fabricate steel mesh	Labor <sup>a</sup>	6996	7061	7147
Fabricate steel mesh	Material	480	480	480
Fabricate steel mesh	Equipment <sup>b</sup>	51	55	73
Install and finish concrete	Labor cost	2837	2837	2837
Install and finish concrete	Material cost	1738	2693	3648
Install and finish concrete	Equipment cost	1648	1648	1648
	Total	20,717	22,092	23,502

<sup>a</sup> Includes cost of specialty technician/robot support for the time the robot is fabricating the steel mesh.

<sup>b</sup> Proportional cost of the robot based on utilization time for the construction of the wall.

Therefore, as the level of complexity increases, the use of robotic fabrication provides significant savings. In addition, the time saving of the different IF options (a reduction of over 50% in the time to build the wall from Option 3 when compared to the current condition) do not have a significant impact, with a reduction of 16% and 19% when comparing the current condition to Option 1 and Option 3, respectively. This low impact is expected given that the time savings derived from the different optimizations are linked to the labor cost during the production of the wire mesh, which accounts for an average cost of about 22% of the total cost for the most likely cost in the current condition and considered options during the robotic construction of the double-curved wall.

4.1.1. Cost structure

The allocation of the different costs (i.e., labor, material, equipment) for the different wall types and construction methods is shown in Fig. 12. The main variations occur in the construction of the concrete



**Table 10**  
Cost for double-curved wall using robotic fabrication.

Task	Cost type	Cost (USD)		
		Optimistic	Most likely	Pessimistic
Produce steel base	Labor	702	1054	1405
Produce steel base	Material	4635	4635	4635
Produce steel base	Equipment	1500	1500	1500
Place AprilTags	Labor	88	88	88
Calibrate IF	Labor	42	42	42
Fabricate steel mesh	Labor <sup>a</sup>	7613	7654	7732
Fabricate steel mesh	Material	566	566	566
Fabricate steel mesh	Equipment <sup>b</sup>	56	59	78
Install and finish concrete	Labor cost	3175	3175	3175
Install and finish concrete	Material cost	1887	2842	3797
Install and finish concrete	Equipment cost	1648	1648	1648
	Total	21,912	23,262	24,665

<sup>a</sup> Includes cost of specialty technician/robot support for the time the robot is fabricating the steel mesh.

<sup>b</sup> Proportional cost of the robot based on utilization time for the construction of the wall.

walls using conventional construction, and they are caused by the high cost of the special formwork needed for the double-curved wall. The relative cost of materials is more than tripled when building the complex wall in the conventional way. In the cases of robotic fabrication, the variations are negligible, and show the closer balance between labor and materials than the conventional construction.

4.2. Hours per installed quantity (h/m<sup>3</sup>)

Contrary to the cost section, the time saving of the different IF options are clearly reflected in the calculation of h/m<sup>3</sup> (Fig. 13). However, the benefits of when robotic fabrication makes sense when compared to conventional construction are more depended on the technical aspects of the robot used. Nevertheless, the different IF optimization options show high reductions in hours per installed quantity compared to conventional construction. The amount of time per unit of installed quantity can be significantly reduced when reasonable modifications are made to the robot system (Fig. 13). Given the advancement in this field, it is expected that future performance would exceed those derived from Option 3. From this perspective, the use of robotic fabrication has significant benefits as the level of complexity increases.

5. Discussion and outlook

A procedure for comparing the productivity based on the total cost and time per unit installed was proposed and successfully applied to the MMW case study at the NEST DFAB HOUSE. The main outcome of the comparison was that the robotic process had higher productivity than a

conventional process for the construction of complex building elements. This section aims to position these results in relation to published literature and discuss unaddressed questions related to the case study. Moreover, future research paths within the field of additive digital fabrication are identified.

5.1. Uncertainty in cost of robot and payback period

This study assumed that the IF has a service life of 90,000 h, which corresponds to the total running time without failures. However, there is high uncertainty related to the service life of this prototype of on-site construction robot. The ISO 15686 standard [49] differences between two service life concepts: the Reference Service Life (RSL) and the Estimated Service Life (ESL). The RSL is defined as the expected service life under normal use and maintenance conditions, which is identified with the physical or technical service life. However, the end of life of the IF can also be influenced by functional or economic factors, which increase or decrease the RSL [61]. For instance, a new model of IF could replace the current one after a period of time. Consequently, the ESL of the current model would be shorter than its RSL of 90,000 h. Nevertheless, due to the ESL uncertainty, the service life considered in the analysis was the technical service life or RSL.

This study assumed that the IF will construct many structures during the 90,000 h of service life. Therefore, the productivity analysis only included the part of robot cost allocated to the construction of one MMW. An alternative approach would be to consider the total cost of the robot system and study when robotic fabrication becomes more economical than conventional construction. Fig. 14 depicts the application of this approach to the MM double-curved wall from the case study previously analyzed. Specifically, the graph shows that robotic construction becomes more cost-efficient when the volume built exceeds about 110 m<sup>3</sup> (i.e., after building 25 walls like the one in the DFAB HOUSE), considering a cost of 125,000 USD for the robot and the modifications for Option 3. This analysis considers that after the 10th wall, the robot IF requires maintenance and repair (assumed to be 5% of the original cost of the robot system used every 10 walls, ignoring robot depreciation). For the conventional construction the special formwork has to be mostly redone (only 10% of its initial cost can be saved) every four walls.

The experimental state of the IF and customized tools needed for the construction process, could considerably increase the costs of a project, making it unrealistic for commercial applications. Consequently, an average cost of 125,000 USD corresponding to an industrial robot was assumed for this mobile robot. However, given the volatility of this field and current trends in the price of robots, it is expected that actual commercial robots similar to the IF would be significantly more economical than the one used for this case study. Therefore, it is expected that in the future the economic savings using robotic fabrication techniques will increase. According to Thayer [50] the price of industrial robots will drop by about 20% by 2025. Considering this fluctuation in the robot cost will make a difference when construction companies

**Table 11**  
Total cost for different wall types (straight and double-curved) and construction methods (conventional and robotic fabrication).

Wall/construction type	Total cost <sup>a</sup> (USD)											
	Current			Option 1			Option 2			Option 3		
	Minimum	Mean	Maximum	Minimum	Mean	Maximum	Minimum	Mean	Maximum	Minimum	Mean	Maximum
Straight/conventional	N/A	7211	N/A	N/A	N/A	N/A	N/A	N/A	N/A	N/A	N/A	N/A
Straight/robot	21,328	22,101	23,035	17,743	18,591	19,558	17,459	18,313	19,281	17,133	17,989	18,950
Double-curved/conventional	45,382	53,955	63,571	N/A	N/A	N/A	N/A	N/A	N/A	N/A	N/A	N/A
Double-curved/robot	22,612	23,268	24,351	18,706	19,465	20,560	18,396	19,163	20,259	18,039	18,812	19,900

<sup>a</sup> Total cost for robotic fabrication includes the proportional cost of robot related to the construction of the wall and cost of specialty technician/robot support for the time the robot is fabricating the steel mesh.

**Table 12**  
Total time (h) for different wall types (straight and double-curved) and construction methods (conventional and robotic fabrication).

Wall/construction type	Total time (h)											
	Current			Option 1			Option 2			Option 3		
	Minimum	Mean	Maximum	Minimum	Mean	Maximum	Minimum	Mean	Maximum	Minimum	Mean	Maximum
Straight/conventional	N/A	24.22	N/A	N/A	N/A	N/A	N/A	N/A	N/A	N/A	N/A	N/A
Straight/robot	67.58	68.76	69.98	40.80	41.87	42.74	38.71	39.76	40.65	33.05	33.69	34.60
Double-curved/conventional	55.12	66.08	76.05	N/A	N/A	N/A	N/A	N/A	N/A	N/A	N/A	N/A
Double-curved/robot	73.83	74.50	75.40	44.57	45.36	46.05	42.29	43.08	43.80	36.10	36.50	37.28

consider taking over this investment. Fig. 15 show a ±20% fluctuation in the robot cost. In the low bound, robots will become economical, when compared to conventional construction, in projects where the volume of concrete exceeds about 88 m<sup>3</sup> (i.e., after building 20 walls like the one in the DFAB HOUSE).

When considering more realistic applications such as the construction of multiple structures (not just one wall as in the cases study), the cost of the robot system will be, due to economies of scale, more competitive making robotic fabrication worth from the economic point of view.

Another important element to be considered has to do with the limitations of the robot utilization. It could be argued that construction robots could work 24 h in a row, given that constant supply of the required resources is provided. This would make the productivity introduced by the robot much more evident. In the case presented in this study, the robot needs manual assistance, and the concept of multiple shifts for construction workers has not been considered, hence the working capacity of the robot is limited by the robot-human interaction.

For simplicity, the cost associated with the commercial dimension of using robotic technology in construction has not been considered. The opportunity of commercialization of this technology for on-site construction applications should be further studied as it could be significant [51]. Future work should account for the factors impacting their commercialization [52] in order to define an approach to prioritize technologies with respect to their innovation potentials [53].

5.2. Sustainable digitalization

The case study analyzed in this paper showed that the MMW achieved a high complexity without additional costs, connected with

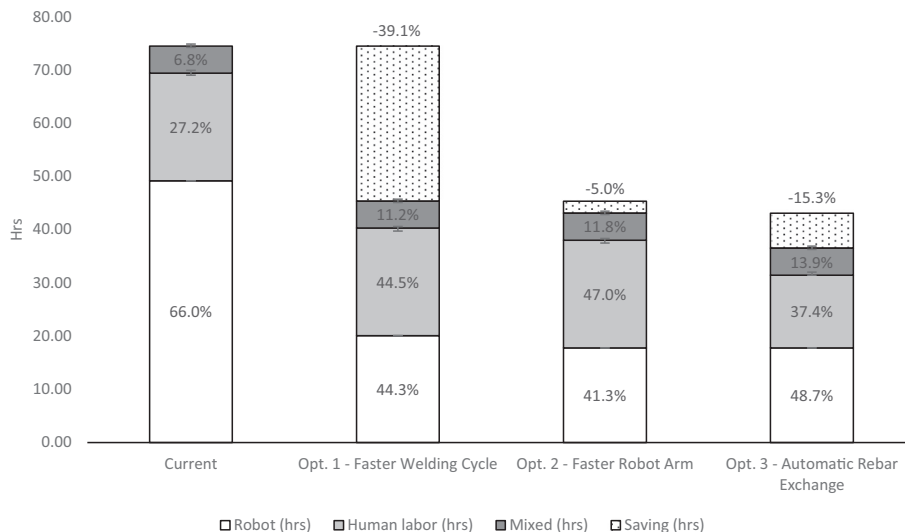

**Fig. 10.** Share of work (% relative to the total time) and saved time (% relative to total time in previous option) for different options for the IF based on mean values.

**Table 13**  
Productivity based on cost per unit quantity installed for each wall and construction type.

Wall/construction type	Productivity (USD/m <sup>3</sup> )			
	Current (1)	Option 1 (2)	Option 2 (3)	Option 3 (4)
Straight/conventional	1639	N/A	N/A	N/A
Straight/robot	5023	4225	4162	4088
Double-curved/conventional	12,262	N/A	N/A	N/A
Double-curved/robot	5288	4424	4355	4276

- (1) Current IF configuration.
- (2) Option 1 – Faster welding cycle.
- (3) Option 2 – Faster robotic arm.
- (4) Option 3 – Automatic rebar exchange.

the avoidance of labor-intensive formworks in the MM process. However, at a lower level of complexity (straight wall), the conventional processes still outperform the MMW process. Similar conclusions were achieved in the environmental evaluation of the MMW presented by Agustí-Juan et al. [45]. Their quantitative study showed that the environmental impact of the MMW does not increase with the uniqueness and complexity of the geometry. In the same way as the present study, the results demonstrated that the benefits of robotic fabrication compared to conventional construction increase proportionally to the level of complexity in the structure. These potential sustainable benefits of additive dfab were already foreseen in previous publications. For instance, Labonnote et al. [14] highlighted the potential of complex structures constructed through additive dfab techniques to reduce material and costs. However, quantitative studies such as the present

**Table 14**  
Productivity based on time per unit quantity installed for each wall and construction type.

Wall/construction type	Productivity (h/m <sup>3</sup> )			
	Current (1)	Option 1 (2)	Option 2 (3)	Option 3 (4)
Straight/conventional	5.50	N/A	N/A	N/A
Straight/robot	15.63	9.52	9.04	7.66
Double-curved/ conventional	15.02	N/A	N/A	N/A
Double-curved/robot	16.93	10.31	9.79	8.30

- (1) Current IF configuration.
- (2) Option 1 – Faster welding cycle.
- (3) Option 2 – Faster robotic arm.
- (4) Option 3 – Automatic rebar exchange.

case study are needed to prove this potential. Next to environmental and cost assessments, the evaluation of social impacts derived from implementing dfab in construction is vital to show the potential of dfab from a complete sustainable perspective (Fig. 16).

The changes in the building industry driven by dfab techniques have a direct impact on the society, especially people working within the construction industry. Dfab will potentially transform the current roles in the planning and execution of construction projects. As robots and other technologies take over tasks previously performed by construction workers, the concern about the future of jobs and wages will increase. Some published studies have anticipated the impact of digitalization in future jobs. According to Hawksworth and Berriman [54], 41% of construction jobs in Germany, 35% in the US, 26% in Japan and 24% in the UK will be probably automated by 2030. However, while dfab will increase productivity, it should not necessarily reduce total employment in the long run. Frey and Osborne [55] point out that low-skill and low-wage occupations are the ones in risk of computerization. According to this study, low-skilled roles will evolve, especially during the transition phase (i.e., human-robot interaction), to new high-skilled roles. As indicated by Gerbert et al. [1], instead of draftsmen there will be a need for workers with digital skills. New roles such as dfab technicians to support robotic systems, dfab programmers to develop computer numerical control, or dfab managers and coordinators are

expected. Other studies [56] have also shown that digitalization is reducing the demand for routine tasks while increasing the demand for low- and high-skilled tasks. These medium-level qualified jobs could be for instance structural engineering certification work or classic architecture design, while on the contrary, on-site jobs, where control and adaptation to fast changing environment and low skilled qualification are required, will always be needed even if adaptation to new tools will happen. However, the exact dimensions of the digital transformation in construction and how it will affect the labor market should be investigated. Based on real construction projects, the elements for a successful transition and integration of dfab in current building processes should be identified. Consequently, an evaluation of dfab impact in the current building industry and its management should be the object of future research studies.

### 5.3. Complex buildings cost less

In this paper, we compared similar structures made with conventional and robotic fabrication techniques. However, the real question is to know if a robotically fabricated product, whatever its shape might be, will be cheaper than current construction practice. To answer this question, one has to know, what does a complex shape provide in terms of economic benefit?

First, one can assume that complexity can be a consequence of a highly integrated construction process. Actually, the conventional organization of the construction is conceived as a successive and layered process where each element and function is addressed by a different element and built at different moments by different skilled workers. It has been recently shown that the combination of functions through the help of digital technologies allows to save time, building materials [26], and therefore money. This functional hybridization when the shape is providing an additional function (e.g. acoustic), clearly requires a higher complexity, which can then be handled with no additional costs by using additive dfab techniques. However, the double curved wall in this study does not belong to this category, as the complex geometry is not used to provide a secondary function and it is only structural.

This leads to the second point of view on the complexity in architecture as a societal necessity. In his book “Complexity and contradiction in architecture”, Venturi [57] stated that the desire for simplicity needs to be combined with the recognition of complexity in

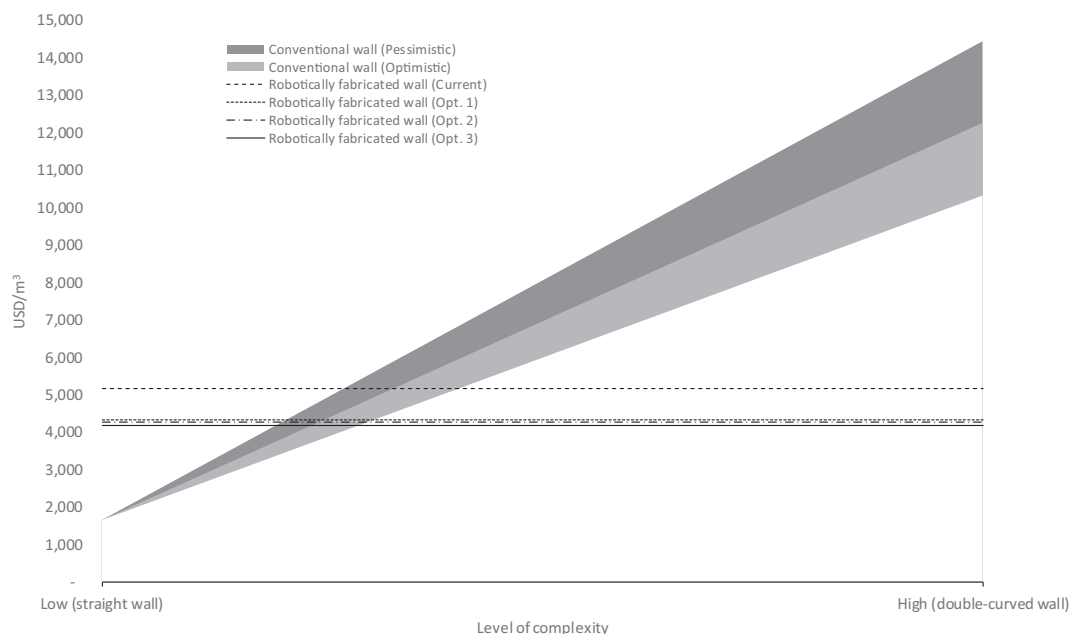

**Fig. 11.** Productivity (USD/m<sup>3</sup>) for different levels of complexity for a concrete wall using conventional construction and robotic fabrication.

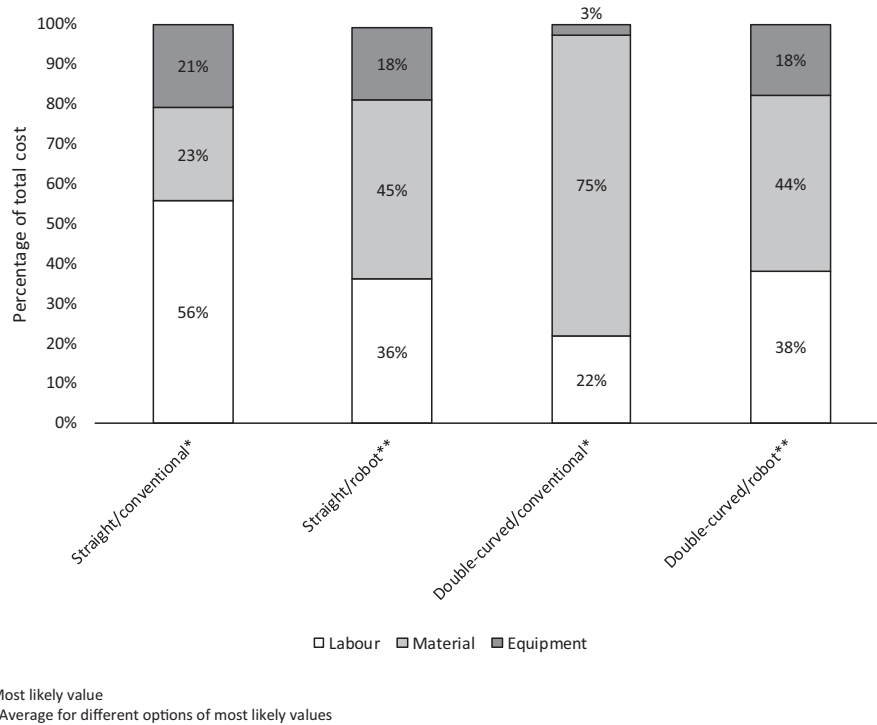

Fig. 12. Allocation of different cost types for each construction method.

\*Most likely value.

\*\*Average for different options of most likely values.

architecture as “aesthetic simplicity which is a satisfaction to the mind derives, when valid and profound, from inner complexity.” Form complexity can also be seen as a pure ornament, and therefore without productive function other than aesthetic, even though it is this exact aesthetic function that relates architecture to culture, form to meaning and finally allows people to identify and relate with empathy to their built environment [58]. Considering this point of view, and having been able to show in this study that the robot was able to produce the ornament with lower cost than the same object produced by a conventional technique, it seems appropriate to consider robotic fabrication as an effective construction technique to produce complex ornamental structures, and to consider that the function of ornament (and the

inherent complexity related to its production) is actually justified by the fact that ornament is a social need [59]. This could justify the use of robotic fabrication for the double curved mesh mold.

Finally, and this has not been much explored in current construction, complex construction forms that could be provided at similar costs as straight ones, could be used to promote more circular buildings. Actually, at the building scale, a circular geometry allows obtaining the same floor area as a squared geometry, but using less material (optimized surface/volume ratio).

As a conclusion, the efficiency of robotic fabrication to produce complex structures compared to conventional construction practice, does not necessarily mean that robotic fabrication is always efficient as

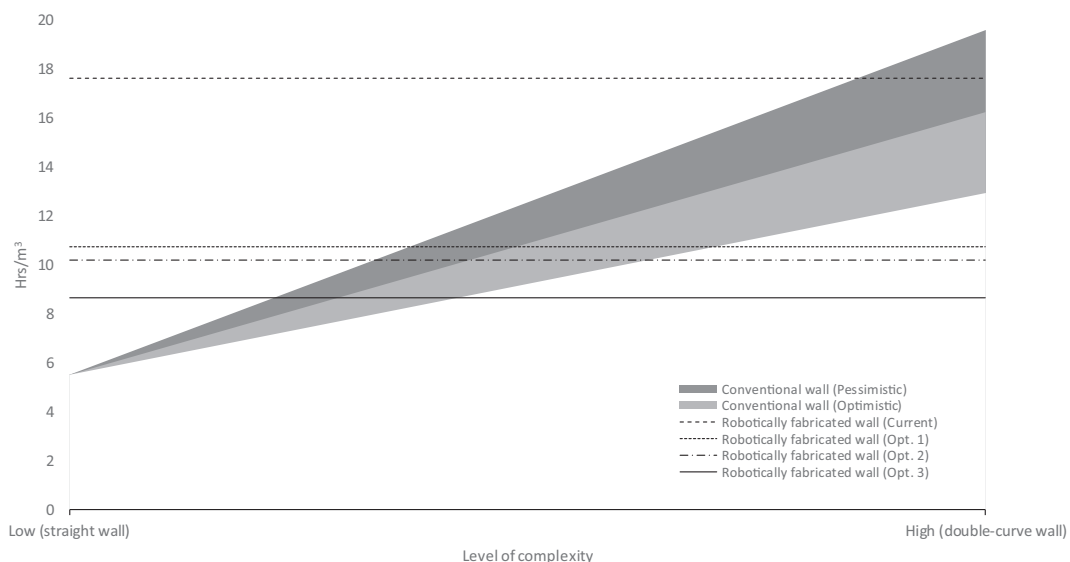

Fig. 13. Productivity (h/m<sup>3</sup>) for different levels of complexity for a concrete wall using conventional construction and robotic fabrication.

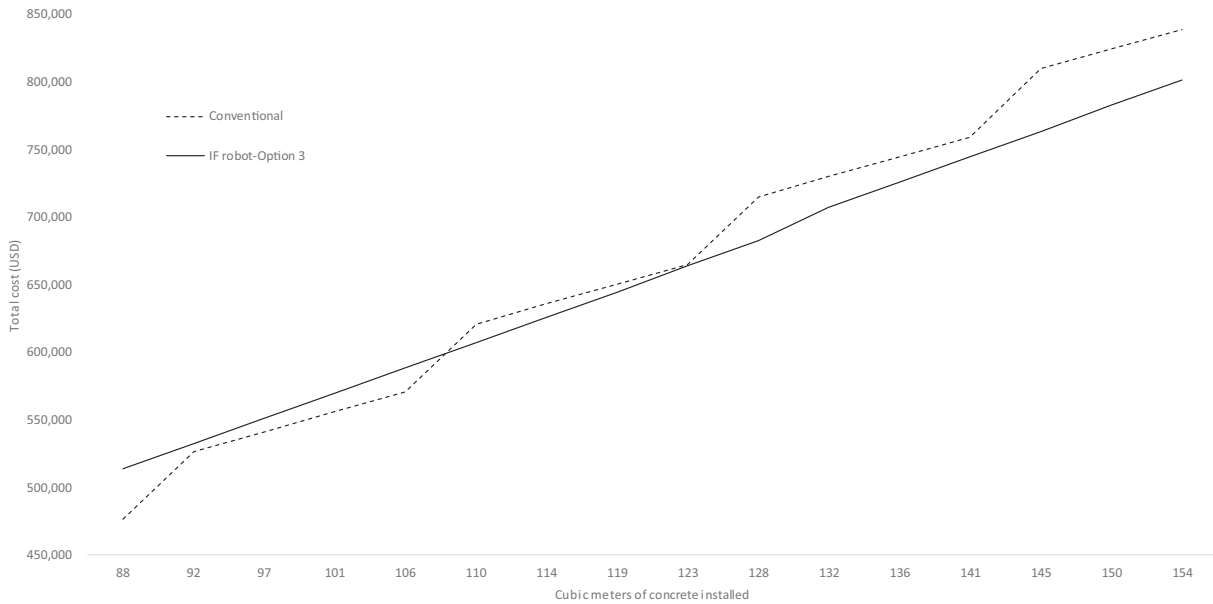

Fig. 14. Break-even analysis between Conventional and IF robot-Option 3 for cubic meters of concrete installed.

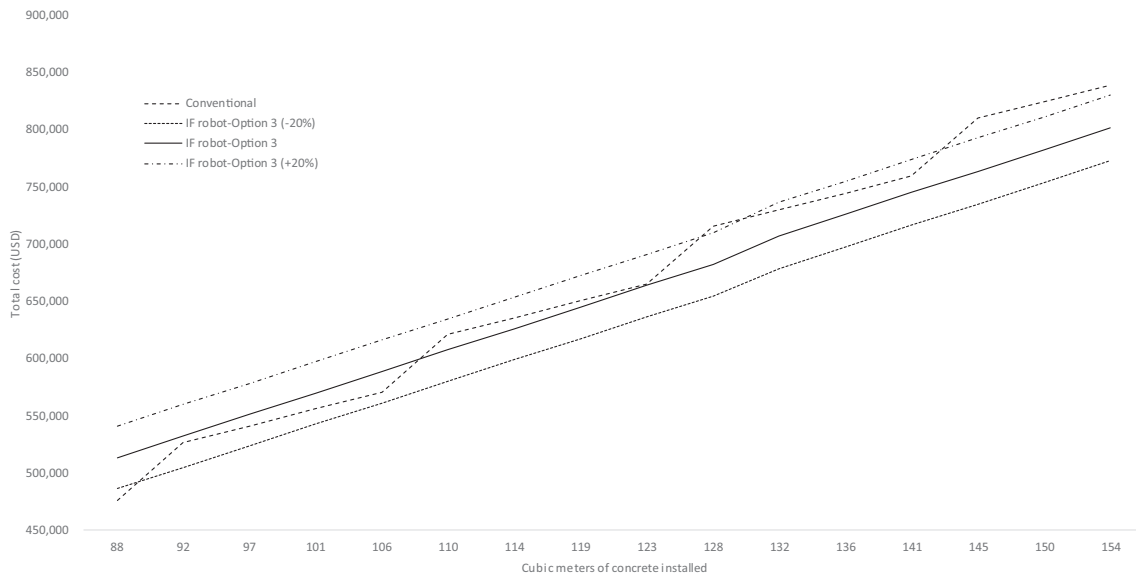

Fig. 15. Break-even analysis between Conventional and IF robot-Option 3 for cubic meters of concrete installed with ±20% fluctuation in robot cost.

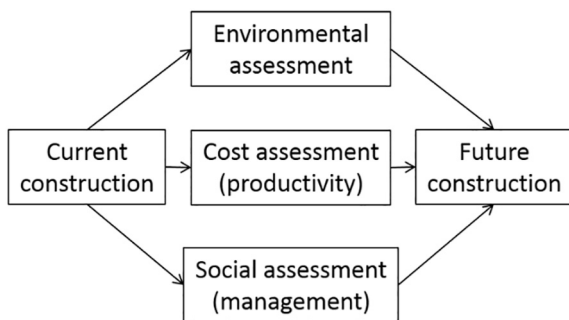

Fig. 16. Requirements for an overall sustainable implementation of dfab in the construction sector.

long as a complex shape is produced. It depends on the final use of this complexity and one can see an advantage if complexity allowed either to reduce the amount of material (circular building vs squared one or

thinner element) or to provide an additional function when the shape is providing a function, being technical through functional hybridization or aesthetic.

## 6. Conclusion

Digital fabrication has shown great potential to move the construction industry into the Digital Age. The integrated digital design and fabrication process (i.e., a design-to-production process) results in more controllability and flexibility during construction, allowing adjustments to be made at a late stage without highly increasing construction costs. Thus, leading to new roles and elements established in the workflow.

This study investigated the effects of additive digital fabrication (dfab) on productivity by analyzing the cost and time required for the construction of a robotically-fabricated complex concrete wall. The CYCLONE simulation technique was used to conduct a quantitative comparison between conventional and robotic construction methods.

The comparison between the two construction processes was done for two types of walls: a doubled-curved wall and a straight wall.

The results demonstrate one example where robotic fabrication provides higher productivity over the conventional construction process when complex structures are built and allows one to imagine the possibilities with other complex structures. The case study also shows that there is no additional cost derived from the robotic fabrication method if the complexity of the wall geometry increases. However, the conventional construction method still outperforms the robotic fabrication method for building simpler walls. The specific cost comparison should be treated as illustrative and not precise and the results from this study should not be extrapolated to draw general conclusion for the broad field of digital fabrication. In addition, some of the data was obtained through simulation or by making reasonable assumptions. As more real applications are conducted, simulated data should be replaced with real data collected from physical experiments. Similarly, as more information becomes available, the assumptions made should be revised and ultimately replaced with actual values.

The Mesh Mould Wall in this study was a motivating example to prove the benefits of digital fabrication in a specific context, while further research is needed to demonstrate the multifaceted impacts that digital fabrication brings to construction process. From this study, it can be stated that additive dfab has the potential to be economically beneficial through the improvement of productivity during the construction of complex structures. Although the MMW is envisioned to work on-site, the unexpected conditions of on-site construction have not been considered in this study. It is important that this kind of robotic systems has this in consideration to have the ability to adjust to uncontrolled environments in a way that does not compromise their productivity. Further research is required to assess the social impacts of using dfab.

## Acknowledgments

This research was supported by the National Centre of Competence in Research, NCCR Digital Fabrication, which was funded by the Swiss National Science Foundation (project number 51NF40\_141853). The authors would like to thank the support from the Mesh Mould Wall team who provided data for the simulation and granted access to the construction site. Special thanks are given to Pascal Breitenstein from ERNE for his support during the work conducted in this study. Thank you also to the anonymous reviewers for their thoughtful comments which have helped to improve the clarity of the paper.

## References

- [1] P. Gerbert, S. Castagnino, C. Rothballer, A. Renz, R. Filitz, The transformative power of building information modeling, March 08, 2016 Boston Consulting Group, <https://www.bcgperspectives.com/content/articles/engineered-products-project-business-digital-engineering-construction/>, (2016), Accessed date: 8 June 2017.
- [2] T. Bock, The future of construction automation: technological disruption and the upcoming ubiquity of robotics, *Autom. Constr.* 59 (2015) 113–121, <http://dx.doi.org/10.1016/j.autcon.2015.07.022>.
- [3] P. Teicholz, Labor-productivity declines in the construction industry: causes and remedies (another look), *AECbytes Blog* 67 (2013) Available at: [http://www.aecbytes.com/viewpoint/2013/issue\\_67.html](http://www.aecbytes.com/viewpoint/2013/issue_67.html), Accessed date: 14 June 2017.
- [4] F. Barbosa, Jonathan Woetzel, Jan Mischke, Maria João Ribeirinho, Mukund Sridhar, Matthew Parsons, Nick Bertram, Stephanie Brown, Reinventing construction: a route to higher productivity, McKinsey Global Institute., (2017) February 2017. Retrieved from: <http://www.mckinsey.com/industries/capital-projects-and-infrastructure/our-insights/reinventing-construction-through-a-productivity-revolution>, Accessed date: 12 April 2017.
- [5] T. Streule, N. Miserini, O. Bartomé, M. Klippel, B. García de Soto, Implementation of scrum in the construction industry, *Procedia Eng.* 164 (2016) 269–276, <http://dx.doi.org/10.1016/j.proeng.2016.11.619>.
- [6] R. Agarwal, S. Chandrasekaran, M. Sridhar, Imagining construction's digital future, Retrieved from <http://www.mckinsey.com/industries/capital-projects-and-infrastructure/our-insights/imagining-construction-digital-future>, (2016), Accessed date: 6 February 2017.
- [7] F. Gramazio, M. Kohler, *Made by Robots: Challenging Architecture at a Larger Scale*, John Wiley & Sons, London, 2014 (ISBN: 978-1-118-53548-6).
- [8] C. Haas, M. Skibniewski, E. Budny, Robotics in civil engineering, *Comput. Aided Civ. Inf. Eng.* 10 (1995) 371–381, <http://dx.doi.org/10.1111/j.1467-8667.1995.tb00298.x>.
- [9] A. Warszawski, Application of robotics to building construction, *Proceedings of the 1st International Symposium on Automation and Robotics in Construction (ISARC)*, Pittsburgh, USA, 1984, <http://dx.doi.org/10.22260/ISARC1984/0003>.
- [10] M.J. Skibniewski, Framework for decision-making on implementing robotics in construction, *J. Comput. Civ. Eng.* 2 (2) (1988) 188–201, [http://dx.doi.org/10.1061/\(ASCE\)0887-3801\(1988\)2:2\(188\)](http://dx.doi.org/10.1061/(ASCE)0887-3801(1988)2:2(188)).
- [11] B. Kolarevic, *Architecture in the Digital Age: Design and Manufacturing*, Taylor & Francis, New York and London, 2003 (ISBN-10: 041538141X).
- [12] E. Stinson, What happens when algorithms design a concert hall? The stunning elbphilharmonie, Available at: <https://www.wired.com/2017/01/happens-algorithms-design-concert-hall-stunning-elbphilharmonie/>, (2017), Accessed date: 26 February 2018.
- [13] N. Dunn, *Digital Fabrication in Architecture*, Laurence King Publishing Ltd, London, 2012 (ISBN 9781856698917).
- [14] N. Labonnote, A. Rønquist, B. Manum, P. Rüter, Additive construction: state-of-the-art, challenges and opportunities, *Autom. Constr.* 72 (2016) 347–366, <http://dx.doi.org/10.1016/j.autcon.2016.08.026>.
- [15] J.P. Sousa, C.G. Palop, E. Moreira, A.M. Pinto, J. Lima, P. Costa, ... A.P. Moreira, The SPIDERobot: a cable-robot system for on-site construction in architecture, *Robotic Fabrication in Architecture, Art and Design*, Springer International Publishing, 2016, pp. 230–239, [http://dx.doi.org/10.1007/978-3-319-26378-6\\_17](http://dx.doi.org/10.1007/978-3-319-26378-6_17).
- [16] B. Khoshnevis, Automated construction by contour crafting—related robotics and information technologies, *Autom. Constr.* 13 (1) (2004) 5–19, <http://dx.doi.org/10.1016/j.autcon.2003.08.012>.
- [17] J. Sklar, Robots lay three times as many bricks as construction workers, MIT Technology Review, 2015 Available at: <https://www.technologyreview.com/s/540916/robots-lay-three-times-as-many-bricks-as-construction-workers/>, Accessed date: 24 April 2017.
- [18] M. Gifftthaler, T. Sandy, K. Dörfler, I. Brooks, M. Buckingham, G. Rey, M. Kohler, F. Gramazio, J. Buchli, Mobile robotic fabrication at 1: 1 scale: the in situ fabrication, *Constr. Robot.* (2017) 1–12, <http://dx.doi.org/10.1007/s41693-017-0003-5>.
- [19] J. Willmann, M. Knauss, T. Bonwetsch, A.A. Apollinarska, F. Gramazio, M. Kohler, Robotic timber construction — expanding additive fabrication to new dimensions, *Autom. Constr.* 61 (2016) 16–23, <http://dx.doi.org/10.1016/j.autcon.2015.09.011>.
- [20] C. Gosselin, R. Duballet, P. Roux, N. Gaudillière, J. Dirrenberger, P. Morel, Large-scale 3D printing of ultra-high performance concrete—a new processing route for architects and builders, *Mater. Des.* 100 (2016) 102–109, <http://dx.doi.org/10.1016/j.matdes.2016.03.097>.
- [21] G. Cesaretti, E. Dini, X. De Kestelier, V. Colla, L. Pambaguian, Building components for an outpost on the Lunar soil by means of a novel 3D printing technology, *Acta Astronautica* 93 (2014) 430–450, <http://dx.doi.org/10.1016/j.actaastro.2013.07.034>.
- [22] S. Keating, N. Oxman, Compound fabrication: a multi-functional robotic platform for digital design and fabrication, *Robot. Comput. Integr. Manuf.* 29 (6) (2013) 439–448, <http://dx.doi.org/10.1016/j.rcim.2013.05.001>.
- [23] F. Gramazio, M. Kohler, *Digital Materiality in Architecture*, Lars Müller Publishers, Baden, Switzerland, 2008 Available at: <https://www.lars-mueller-publishers.com/digital-materiality-architecture> (ISBN: 978-303778-122-7).
- [24] S. Lim, R.A. Buswell, T.T. Le, S.A. Austin, A.G. Gibb, T. Thorpe, Developments in construction-scale additive manufacturing processes, *Autom. Constr.* 21 (2012) 262–268, <http://dx.doi.org/10.1016/j.autcon.2011.06.010>.
- [25] Apis Cor, How do we save up construction costs? Retrieved from <http://apis-cor.com/en/3d-printer#article-price>, Accessed date: 3 October 2017(n.d.).
- [26] I. Agustí-Juan, G. Habert, Environmental design guidelines for digital fabrication, *J. Clean. Prod.* 142 (2017) 2780–2791, <http://dx.doi.org/10.1016/j.jclepro.2016.10.190>.
- [27] National Research Council, *Advancing the competitiveness and efficiency of the US construction industry*, Available at: National Academies Press, <http://nap.edu/12717>, (2009), Accessed date: 15 September 2017.
- [28] M.E. Shehata, K.M. El-Gohary, Towards improving construction labor productivity and projects' performance, *Alex. Eng. J.* 50 (4) (2011) 321–330, <http://dx.doi.org/10.1016/j.aej.2012.02.001>.
- [29] S.P. Dozzi, S.M. AbouRizk, *Productivity in Construction*, Institute for Research in Construction, National Research Council, Ottawa, 1993, p. 44 (ISBN 0-662-21134-0).
- [30] W. Yi, A.P. Chan, Critical review of labor productivity research in construction journals, *J. Manag. Eng.* 30 (2) (2013) 214–225, [http://dx.doi.org/10.1061/\(ASCE\)ME.1943-5479.0000194](http://dx.doi.org/10.1061/(ASCE)ME.1943-5479.0000194).
- [31] A. Warszawski, Economic evaluation of robotics in building, *Proceedings of the 1st International Symposium on Automation and Robotics in Construction (ISARC)*, Pittsburgh, USA, 1984, <http://dx.doi.org/10.22260/ISARC1984/0004>.
- [32] M. Skibniewski, C. Hendrickson, Analysis of robotic surface finishing work on construction site, *J. Constr. Eng. Manag.* 114 (1) (1988) 53–68, [http://dx.doi.org/10.1061/\(ASCE\)0887-3801\(1988\)2:2\(188\)](http://dx.doi.org/10.1061/(ASCE)0887-3801(1988)2:2(188)).
- [33] F.T. Najafi, X. Fu, Economic evaluation of robots in construction, 9th International Symposium on Automation and Robotics in Construction (ISARC), Tokyo, Japan, 1992, <http://dx.doi.org/10.22260/ISARC1992/0027>.
- [34] C. Balaguer, A. García, J.M. Pastor, L.F. Peñín, Evaluation and comparative study of robotics vs manual spraying of GRC panels, 12th International Symposium on Automation and Robotics in Construction (ISARC), Warsaw (Poland), 1995, <http://dx.doi.org/10.22260/ISARC1995/0059>.
- [35] D. Castro-Lacouture, L.S. Bryson, C. Maynard II, R.L.W., P. Bosscher, Concrete paving productivity improvement using a multi-task autonomous robot, *Proceedings of the 24th International Symposium on Automation and Robotics in*

- Construction (ISARC), Kochi, India, 2007, <http://dx.doi.org/10.22260/ISARC2007/0040>.
- [36] A. Warszawski, Y. Rosenfeld, Robot for interior-finishing works in building: feasibility analysis, *J. Constr. Eng. Manag.* 120 (1) (1994) 132–151, [http://dx.doi.org/10.1061/\(ASCE\)0733-9364\(1994\)120:1\(132\)](http://dx.doi.org/10.1061/(ASCE)0733-9364(1994)120:1(132)).
- [37] S.M. AbouRizk, S.A. Hague, R. Ekyalimpa, Construction simulation: an introduction to using symphony, Available at: Hole School of Construction Engineering, Department of Civil & Environmental Engineering, University of Alberta, <http://development.construction.ualberta.ca/simphony40/Manuals/SimulationBook.pdf>, (2016) , Accessed date: 24 April 2017.
- [38] S. Plotner, Building construction data, RS Means, 74th annual edition, 2016 (ISBN-10: 1943215014).
- [39] Empa, DFAB HOUSE – digital fabrication and living, Available at: <https://www.empa.ch/web/nest/digital-fabrication>, (2017) , Accessed date: 14 December 2017.
- [40] N. Hack, T. Wangler, J. Mata-Falcón, K. Dörfler, N. Kumar, A. Walzer, K. Graser, L. Reiter, H. Richner, J. Buchli, W. Kaufmann, R.J. Flatt, F. Gramazio, M. Kohler, Mesh Mould: an on site, robotically fabricated, functional formwork, *Concrete Innovation Conference HPC/CIC. Tromsø, Norway*, 2017.
- [41] N. Hack, W. Lauer, F. Gramazio, M. Kohler, Mesh Mould: robotically fabricated metal meshes as concrete formwork and reinforcement, *Proceedings of the 11th International Symposium on Ferrocement and 3rd ICTRC International Conference on Textile Reinforced Concrete*, Aachen, Germany, June 2015, pp. 7–10.
- [42] NCCR, Digital fabrication, Available at: <http://www.dfab.ch/achievements/building-with-robots-and-3d-printers-construction-of-the-dfab-house-up-and-running/>, (2017) , Accessed date: 24 September 2017.
- [43] E. Olson, AprilTag: a robust and flexible visual fiducial system, 2014 IEEE International Conference on Robotics and Automation (ICRA), Hong Kong, 2014, pp. 4493–4499, , <http://dx.doi.org/10.1109/ICRA.2014.6907515>.
- [44] US DoL, United States Department of Labor. May 2016 State occupational employment and wage estimates, New York, Available at [https://www.bls.gov/oes/current/oes\\_ny.htm](https://www.bls.gov/oes/current/oes_ny.htm), (2016) , Accessed date: 8 September 2017.
- [45] I. Agustí-Juan, F. Müller, N. Hack, T. Wangler, G. Habert, Potential benefits of digital fabrication for complex structures: environmental assessment of a robotically fabricated concrete wall, *J. Clean. Prod.* 154 (2017) 330–340, <http://dx.doi.org/10.1016/j.jclepro.2017.04.002>.
- [46] J. Tilley, Automation, robotics, and the factory of the future, Available at: McKinsey and Company, <https://www.mckinsey.com/business-functions/operations/our-insights/automation-robotics-and-the-factory-of-the-future>, (2017) , Accessed date: 12 September 2017.
- [47] RobotWorx, How much do industrial robots cost? Retrieved from <https://www.robots.com/faq/show/how-much-do-industrial-robots-cost> , Accessed date: 3 October 2017(n.d.).
- [48] Symphony.NET 4.6, Release Build 4.6.0.272 2017-08-11, University of Alberta, 2017 Available at: <http://development.construction.ualberta.ca/simphony40/>.
- [49] ISO, 15686-1: 2000: Buildings and constructed assets-service life planning-part 1: general principles, Available at: <https://www.iso.org/standard/28702.html>, (2000) , Accessed date: 23 June 2017.
- [50] K. Thayer, What is the real cost of an industrial robot arm? Retrieved from <http://insights.globalspec.com/article/4788/what-is-the-real-cost-of-an-industrial-robot-arm>, (2017) , Accessed date: 3 October 2017.
- [51] R. Bandarian, Evaluation of commercial potential of a new technology at the early stage of development with fuzzy logic, *J. Technol. Manag. Innov.* 2 (4) (2007) 73–85 (Jan. 2008, ISSN 0718-2724).
- [52] V. Zemlickienė, A. Mačiulis, M. Tvaronavičienė, Factors impacting the commercial potential of technologies: expert approach, *Technol. Econ. Dev. Econ.* 23 (2) (2017) 410–427, <http://dx.doi.org/10.3846/20294913.2016.1271061>.
- [53] T. Dereli, K. Altun, A novel approach for assessment of candidate technologies with respect to their innovation potentials: quick innovation intelligence process, *Expert Syst. Appl.* 40 (3) (2013) 881–891, <http://dx.doi.org/10.1016/j.eswa.2012.05.044>.
- [54] J. Hawksworth, R. Berriman, UK economic outlook, PwC, (2017) March 2017. Available at: <http://www.pwc.co.uk/economic-services/ukeo/pwc-uk-economic-outlook-full-report-march-2017-v2.pdf> , Accessed date: 24 April 2017.
- [55] C.B. Frey, M.A. Osborne, The future of employment: how susceptible are jobs to computerisation? *Technol. Forecast. Soc. Chang.* 114 (2017) 254–280, <http://dx.doi.org/10.1016/j.techfore.2016.08.019>.
- [56] OECD, Policy Brief on the Future of Work: Automation and Independent Work in a Digital Economy, OECD Publishing, Paris, 2016 Available at: <https://www.oecd.org/employment/Automation-and-independent-work-in-a-digital-economy-2016.pdf> , Accessed date: 12 December 2017.
- [57] R. Venturi, Complexity and Contradiction in Architecture, 2nd edition, *The Museum of Modern Art, New York*, 1977 (ISBN: 978-0870702822).
- [58] W. Rosenbauer, The function of ornament, *Coll. Art J.* 6 (3) (1947) 222–225. Available at: <http://www.jstor.org/stable/772972> , Accessed date: 14 December 2017.
- [59] F. Moussavi, M. Kubo, *The Function of Ornament*, Harvard Graduate School of Design/Actar Publishers, 2008 (ISBN-10: 8496540502).
- [60] G. Hunt, F. Mitzalis, T. Alhinai, P.A. Hooper, M. Kovac, 3D printing with flying robots, 2014, IEEE International Conference on Robotics and Automation (ICRA), Hong Kong, 2014, pp. 4493–4499, <http://dx.doi.org/10.1109/ICRA.2014.6907515>.
- [61] A. Silva, J. de Brito, P.L. Gaspar, Methodologies for service life prediction of buildings: with a focus on façade claddings, Springer, 2016, <http://dx.doi.org/10.1007/978-3-319-33290-1> (ISBN 978-3-319-33288-8).